

RESEARCH

Open Access



# Adaptation and validation into Spanish of the brief scale of mood regulation through music (B-MMR)

Miguel-Ángel Hermida<sup>1\*</sup>, David Tomé-Lourido<sup>2</sup> and Ana Isabel Pereira<sup>3</sup>

## Abstract

**Background** Music plays a crucial role in mood regulation by influencing emotions, reducing stress, and enhancing overall well-being. Few instruments measure the use of music as a mood regulatory strategy. This study aimed to adapt and validate the Brief Music in Mood Regulation Scale (B-MMR), a 21-item self-report instrument, to the Spanish language.

**Method** Data was analysed from 429 Spanish students and was collected between September and December 2024. The B-MMR was used alongside the Basic Emotions Questionnaire. A confirmatory factor analysis, reliability, invariance analysis and external validity tests were conducted.

**Results** Confirmatory factor analysis of the B-MMR with 7 factors and 3-item each demonstrated robust indicators of global adjustment replicating the original structure of the questionnaire, as well as satisfactory reliability and validity data. The invariance analysis showed homogeneity in the measurement model.

**Conclusions** The Spanish version of the B-MMR is a valuable instrument to further understand music's psychological impact on mood in the Spanish population.

**Keywords** Mood regulation, Test adaptation and validation, Music, Confirmatory factorial analysis, Emotion regulation

## Introduction

The ability of music to evoke emotional states is a field of research that has been cultivated from various scientific disciplines in recent years. Studies on the reaction of listeners to music are a complex aspect to consider. In this sense, Juslin et al. [27] identify the challenge of measuring

the degree of emotional affectation through the multiple parameters that comprise it, not only from a musical technical perspective, but also in the context of the environment in which listening occurs and the associated memories and emotions. The aspects of the brain that are affected during music listening affect regions where memory, expectation, and emotion are developed [39]. In this sense, Eerola [11] explores the identification of basic emotions in music beyond the reactions triggered from a biological perspective. Basic emotions are considered present in any affective development program, regardless of the specialties and areas in which it is developed. The concept of basic emotions, identified as anger, fear, surprise, sadness, disgust, contempt, and happiness, is

\*Correspondence:

Miguel-Ángel Hermida  
miguel.lopez.hermida@udc.es

<sup>1</sup>Faculty of Education, Universidade da Coruña, A Coruña, Spain

<sup>2</sup>Facultad de Ciencias de la Salud, Universidad Internacional de La Rioja, Logroño, Spain

<sup>3</sup>Faculdade de Ciências Sociais e Humanas, Universidade Nova de Lisboa, CESEM, Lisboa, Portugal



© The Author(s) 2026. **Open Access** This article is licensed under a Creative Commons Attribution-NonCommercial-NoDerivatives 4.0 International License, which permits any non-commercial use, sharing, distribution and reproduction in any medium or format, as long as you give appropriate credit to the original author(s) and the source, provide a link to the Creative Commons licence, and indicate if you modified the licensed material. You do not have permission under this licence to share adapted material derived from this article or parts of it. The images or other third party material in this article are included in the article's Creative Commons licence, unless indicated otherwise in a credit line to the material. If material is not included in the article's Creative Commons licence and your intended use is not permitted by statutory regulation or exceeds the permitted use, you will need to obtain permission directly from the copyright holder. To view a copy of this licence, visit <http://creativecommons.org/licenses/by-nc-nd/4.0/>.

complex in its definition and composition, particularly from a biological perspective [14, 15]. Emotions are a mechanism that human beings have to express themselves and adapt to their surroundings. The ability to connect emotions with feelings (rational interpretations of them), mediated by evoked musical listening, stands out as one of the most impactful and complex activities [42].

#### **The social and emotional functions of music in daily life**

Listening to music is a socially expanded daily activity [31]. Its use as a daily tool in the face of daily stress is an established habit in today's society. The taste for music is awakened through the activation of neural circuits called nodes, which favour the recognition of the music enjoyed by each listener in each situation [1, 32]. The neural circuit connects the imagination of waiting for listening with the experience of this listening. The contextual scope, in turn, influences these circuits. New elements are added to the imagination and expectation in the musical experience, such as the company in front of which the musical experience is produced, which enlarge and enhance the experience by increasing empathy. The person you share the experience with influences the outcome of listening and the ability to increase emotional sensations [52]. From the perspective of emotional stability, listeners choose the type of music according to the emotional purpose they pursue, intending to enhance or reverse these states [44]. Cascarino et al. [10] establish the ability to select musical styles and genres according to the degree of affectation to emotional well-being. Empathy and musical sensitivity are related as a conditioning factor to show greater sensitivity towards it [9]. Lonsdale and North [36] delve into the motives and reasons that lead the population to listen to music. Its social function revolves around three elements: self-identity, interpersonal relationships, and emotional regulation. Emotional regulation and the expression of feelings are conveyed through music, and in turn, music becomes a link for the recovery of memories associated with lived moments [41].

Distraction is another fundamental reason for listening to music. In this sense, Krause et al. [30] delve into the times of day it is used and its intensity, depending on the context. Contact with music is a daily and constant occurrence. Their studies show that the reasons for selecting different musical genres are based on strictly musical issues from the listeners' perspective, and in turn, on issues related to mood and emotional regulation, which are decisive when it comes to selection. The richness of musical styles allows the emotional use of music in different ways, depending on the type of listener. Saarikallio et al. [49] explore the impact of music on self-efficacy, well-being, self-regulation, and the sense of agency, which is understood as the ability to control the

world in which adolescents' lives develop. Music provides them with a tool that offers a multitude of possibilities, depending on the diversity of musical styles. All this contributes to music listening, a daily activity that is becoming a compendium of rewarding benefits from both an emotional and psychological perspective [49].

#### **Contextual and emotional determinants of music listening behaviour**

Among the important aspects regarding the contextual environment in which music listening is consumed, the type of genre and musical form are included, which influence the listener's behavior due to the impact of their sound characteristics. This means that, depending on the variability of parameters related to emission volume, the type of harmonic progressions, and the repetition of rhythmic patterns, the emotional effects of music are different [53]. In this regard, the contributions of Hargreaves and North [21] stand out, as they analyze the differences in environment and context that condition the influence of music on listeners. Each of the multiple styles and its sub-styles is composed of specific musical patterns and elements at the harmonic, melodic, and rhythmic levels, which generate diverse responses at the physical and neural levels in the listener. This is due to the reactivity of the sound frequency spectrum, which influences the human body and has a positive or negative effect depending on the intensity threshold at which it occurs [23]. Music not only produces effects because of its technical and artistic elements but also creates them according to the intellectual and social part of the context in which it develops [16].

Another important aspect focuses on the type of emotional affectation of music as a function of musical self-selection. In this sense, they establish and evaluate the differentiation between self-selected music and non-self-selected music, focusing on their capacity to affect emotional regulation. Groarke and Hogan [20] establish that music listening is a complex intervention with a series of potential mechanisms that underlie its regulatory effects, higher for self-selection. According to Liljeström et al. [34], music chosen by oneself tends to increase positive emotions, whereas music listened to randomly tends to increase negative emotions [43]. Herrera et al. [24] delve into the role of music selected for listening by adolescents in their aesthetic and behavioral aspects with respect to sociability and self-perception within the field of evolutionary social psychology. The ability to perceive emotions can be influenced by the context in which music has a prominent presence, and this latter factor is a significant determinant of emotional alteration [17]. In this sense, Greb et al. [19] highlight that the emotional impact of listening to music varies depending on the contextual and situational situations of the listeners. The importance

of mood in the decision to listen to music is a significant predictor of nearly all aspects of music listening.

### **Music and mood regulation: clinical applications and measurement instruments**

Based on a previous review, it is considered that music influences parameters such as emotional impact, mood, and affective states [3]. Its applicability extends to multiple everyday and even clinical settings. Its application as a tool for emotional improvement in patients within the clinical setting has increased in recent years, yielding positive results [5, 35]. The ability to manage affective and emotional states is of paramount importance for human beings, as it enables them to regulate their appearance and emotional intelligence. It is necessary to differentiate between moods and emotions by their longer duration over time. Both are connected by aspects that awaken them, encompassing psychophysiological, behavioural, and subjective elements [48]. The control and regulation of mood influences and determines affective states.

The ability of music to affect these aspects is not a phenomenon that can be averaged equally across all situations and listeners. Exposure to music seems to affect the mood of listeners and produce different emotional reactions depending on the musical style and social context in which it is heard. Despite advancements in this area, we still lack adequate measurement tools to assess how music listening affects students. Therefore, it is essential to validate the B-MMR scale [48] in Spanish, providing an instrument to measure these effects within Spanish-speaking populations. Even starting from this assumption, few instruments measure the influence of music on its ability to affect these parameters. One of these is the *Music in Mood Regulation* (MMR) instrument, available in its 40-item version [46] and its 21-item version (B-MMR) [48]. These scales encompass various dimensions that aim to assess the impact of music listening as a mediator of emotional and affective states in listeners. The dimensions that make up the scale are a total of 7: Entertainment (ability to create a positive environment); Reactivation (measuring the capacity for emotional renewal and stress reduction); Intense Sensation (ability to induce high-intensity emotional states); Distraction (ability to abstract from negative feelings and thoughts); Discharge (ability to evoke negative emotions); Mental work (ability to concentrate mentally through listening to music); Consolation (capacity for understanding and emotional redemption through music). The purpose of this instrument is to measure the capacity of music as an element of activation of different affective states and the ability to evoke emotional responses through listening to music, regardless of the genres and styles selected.

The main objective of this study was to adapt and validate the 21-item version of the B-MMR scale [48], which

demonstrates stronger psychometric properties than the original 40-item MMR version [46]. The specific aims were: (1) to assess whether these properties are retained in the Spanish adaptation, ensuring a reliable instrument for current and future research; and (2) to examine its external validity by analyzing its relationship with the basic emotions identified by Ekman and Cordaro [15], adapted to assess emotional responses to music. The general hypothesis was that the Spanish version would replicate the original factorial structure and exhibit satisfactory levels of internal consistency, reliability, and validity.

## **Methodology**

### **Participants**

The study included 429 Spanish students, selected using heterogeneous purposive sampling [37]. This method was appropriate given the variability in musical perception and emotional response, and the limited accessibility of the target population. Of these, 141 identified themselves as men (32.9%), 274 as women (63.9%) and 12 as undefined sex (2.8%). The ages of the participants ranged from 16 to 75 years ( $M = 24.07$ ;  $SD = 11.55$ ). All were enrolled in Spanish educational institutions: 51.8% were in vocational training, 36.4% were studying secondary or baccalaureate, and 11.4% were attending university.

### **Instruments**

The Spanish adaptation of the Brief Music in Mood Regulation (B-MMR) scale [48] was carried out. This self-report instrument consists of 21 items distributed in 7 factors, with three items in each.

To justify the theoretical model underlying the questionnaire's structure, the framework proposed by Saarikallio [48] was followed, as it offers a comprehensive and empirically grounded understanding of how adolescents use music for mood regulation. Developed through qualitative research involving teenagers aged 14 to 18, the model emerged from an inductive analysis of personal experiences with music in everyday life. By employing grounded theory methods, Saarikallio identified seven distinct emotional regulation strategies that adolescents engage in through musical activities. These strategies reflect a range of purposes, from seeking enjoyment and relaxation to managing negative emotions and fostering introspection. Given its detailed conceptualization of the emotional functions of music, this model provides a suitable and well-structured basis for the present study.

The answers are collected using a 5-point Likert scale, where 1 indicates "strongly disagree" and 5 "strongly agree". The original version demonstrated satisfactory reliability, as all factors presented a Cronbach's alpha score higher than .73, in addition to exhibiting adequate

indicators of external validity in relation to emotional regulation instruments.

Participants were also asked to answer the question “How do you feel when listening to music?” to assess, on a scale of 1 = not at all to 5 = a lot, the intensity of the seven basic emotions proposed by Ekman and Cordaro [15]: anger, fear, surprise, sadness, disgust, contempt, and happiness.

### Procedure

To adapt the questionnaire to Spanish, the steps recommended by Balluerka et al. [4] and Muñiz et al. [38] were followed, along with the criteria proposed by the Guidelines of the International Test Commission [22]. The process involved translating the items from the original language, English, to Spanish, followed by a reverse translation from Spanish back to English. Two researchers, each with proficiency in both languages, performed the translations independently. A committee of experts in musicology and psychology reviewed the translated wording of the items, ensuring that the statements were clear and that the original meaning was preserved. After completing this stage, the final data collection was conducted to validate the instrument’s adaptation empirically.

This study received approval from the Bioethics Committee of the University of A Coruña (#2023-029, March 7, 2024) prior to commencing data collection. After obtaining this approval, the sample size necessary to ensure that the sample was representative of the Spanish student population was calculated, using the formula for infinite populations proposed by Cochran [13]. It was determined that the minimum sample size should be 400 participants. The questionnaire was administered online, and the inclusion criteria were: (a) to be a student of formal education in Spanish educational institutions and (b) to be 16 years of age or older.

The data was collected between September and December 2024. Before completing the questionnaire, participants were informed about the anonymity of their responses, the voluntary nature of their participation, and their right to withdraw from the survey at any time. They were also informed that their data would be treated confidentially, in compliance with Regulation (EU) 2016/679 and Organic Law 3/2018, of 5 December, on the protection of personal data and guarantee of digital rights. All participants gave their informed consent voluntarily. The study was conducted in accordance with the principles outlined in the Declaration of Helsinki.

### Data analysis

The analyses were performed using the IBM SPSS version 25 and IBM AMOS version 22 statistical packages. First, descriptive statistics were calculated for the 21

items of the questionnaire. Then, a confirmatory factor analysis was performed, estimating the parameters using the Maximum Likelihood method. Next, the reliability of the factors obtained from the measurement model was evaluated using two methods: internal consistency, by calculating  $\alpha$  the Cronbach model, and composite reliability. The average variance extracted from each factor was also calculated to estimate its convergent and discriminant validity. Then, an invariance analysis of the measurement model was carried out to verify the equivalence of the factor structure, considering sex as a moderating variable in a multigroup analysis: men (32.9% of participants) and women (63.9%). Two models were compared: one without restrictions in the estimation of parameters for both groups (unconstrained) and another with the constraint of equalizing the factor loads between the groups (constrained). Finally, an analysis of the external validity of the questionnaire was carried out, using correlations between the factors of the B-MMR and the basic emotions that music generated in the participants. Spearman’s correlations were performed because some variables did not meet the assumption of normality, despite the dataset exhibited a multivariate normal distribution.

## Results

### Descriptive statistics

Table 1 presents the descriptive statistics of the items in Spanish of the MMR-B scale. The mean values ( $M$ ) ranged from 2.58 (item 13) to 4.59 (item 2). The highest standard deviation ( $SD$ ) recorded was 1.49 (item 14). Most of the items showed negative asymmetry indexes (16 items) and negative kurtosis (17 items). Likewise, Table 1 includes the factor loadings ( $\lambda$ ) of the 21 items corresponding to the model specified in the confirmatory analysis.

### Confirmatory analysis

The original model of the reduced version [48] was replicated, which consisted of 7 factors with 3 items each. The distribution of items by factor can be seen in Fig. 1. All factor loads and variances of errors were statistically significant ( $p < .001$ ). The goodness-of-fit indices can be found in Table 2.

### Reliability and average variance extracted

As shown in Table 3, all reliability indicators exceeded the threshold of 0.8. Likewise, the average variance extracted (AVE) is reported, which is greater than 0.5 in all factors.

The AVE of each B-MMR factor exceeded the squared correlations between the construct and other latent variables. As shown in Table 4, the Spearman’s correlations among constructs are lower than the square root of each construct’s AVE.

**Table 1** Descriptive statistics and factor load of B-MMR items

Items	M	SD	Asymmetry	Kurtosis	$\lambda$
MMR 1 When I'm busy around the house and no one else is around, I like to have some music on the background [Cuando estoy ocupado en casa y no hay nadie más alrededor, me gusta tener música de fondo]	4.4	0.95	-1.81	3.07	0.81
MMR 2 I listen to music to make cleaning and doing other housework more pleasant [Escucho música para hacer que la limpieza y otras tareas domésticas sean más agradables]	4.59	0.81	-2.32	5.59	0.68
MMR 3 I usually put background music on to make the atmosphere more pleasant [Normalmente pongo música de fondo para hacer el ambiente más agradable]	4.04	1.09	-0.84	-0.28	0.7
MMR 4 When I'm tired out, I rest by listening to music [Cuando estoy cansado, descanso escuchando música]	3.03	1.37	0.03	-1.21	0.63
MMR 5 I listen to music to perk up after a rough day [Escucho música para animarme después de un día difícil]	4.04	1.17	-1.06	0.08	0.79
MMR 6 When I'm exhausted, I listen to music to perk up [Cuando estoy agotado, escucho música para animarme]	3.67	1.27	-0.57	-0.73	0.8
MMR 7 I feel fantastic putting my soul fully into the music [Me siento genial poniendo mi alma completamente en la música]	3.95	1.2	-0.94	-0.05	0.86
MMR 8 Music has offered me magnificent experiences [La música me ha ofrecido experiencias magníficas]	4.35	0.98	-1.65	2.34	0.76
MMR 9 I want to feel the music in my whole body [Quiero sentir la música en todo mi cuerpo]	3.82	1.23	-0.68	-0.63	0.8
MMR 10 When stressful thoughts keep going round and round in my head, I start to listen to music to get them off my mind [Cuando los pensamientos estresantes siguen dando vueltas y vueltas en mi cabeza, empiezo a escuchar música para sacarlos de mi mente]	3.64	1.25	-0.57	-0.75	0.85
MMR 11 For me, music is a way to forget about my worries [Para mí, la música es una forma de olvidarme de mis preocupaciones]	3.79	1.2	-0.68	-0.55	0.84
MMR 12 When I feel bad, I try to get myself in a better mood by engaging in some nice, music-related activity [Cuando me siento mal, trato de ponerme de mejor humor participando en alguna actividad agradable relacionada con la música]	3.27	1.3	-0.19	-1.04	0.63
MMR 13 When I'm angry with someone, I listen to music that expresses my anger [Cuando estoy enfadado con alguien, escucho música que expresa mi enfado]	2.58	1.46	0.46	-1.17	0.88
MMR 14 When I'm really angry, I feel like listening to some aggressive music [Cuando estoy realmente enfadado, empiezo a escuchar música que expresa esos sentimientos]	2.69	1.49	0.35	-1.29	0.95
MMR 15 When everything feels bad, it helps me to listen to music that expresses my bad feelings [Cuando todo va mal, me ayuda escuchar música que exprese mis malos sentimientos]	3.12	1.48	-0.08	-1.39	0.78
MMR 16 Music has helped me to get through hard experiences [La música me ha ayudado a superar experiencias difíciles]	3.56	1.36	-0.55	-0.91	0.83
MMR 17 Music helps me to recognize different feelings in myself [La música me ayuda a entender diferentes sentimientos en mi interior]	3.56	1.32	-0.57	-0.78	0.85
MMR 18 When I'm distressed by something, music helps me to clarify my feelings [Cuando estoy angustiado por algo, la música me ayuda a aclarar mis sentimientos]	3.31	1.33	-0.3	-1.04	0.88
MMR 19 I listen to music to find solace when worries overwhelm me [Escucho música para encontrar consuelo cuando las preocupaciones me abruma]	3.37	1.35	-0.36	-1.05	0.87
MMR 20 When everything feels bad, music understands and comforts me [Cuando todo va mal, la música me entiende y me consuela]	3.31	1.39	-0.28	-1.19	0.88
MMR 21 When I'm feeling sad, listening to music comforts me [Cuando me siento triste, escuchar música me reconforta]	3.88	1.23	-0.92	-0.13	0.79

Standard error for asymmetry=0.12; Standard error for kurtosis=0.24;  $\lambda$ = factor loading

### Invariance

Table 5 shows the fit indices for the unconstrained model and the constrained model. The difference between the CFI indicator of both models was not greater than .01. In addition, no statistically significant differences were found between the two models ( $\chi^2_{\text{dif}}(21) = 24.06; p = .29$ ).

### External validity

Finally, Table 6 presents Spearman's correlations between the factors of the Spanish version of the B-MMR and the basic emotions (anger, fear, surprise, sadness, disgust, contempt, and happiness). All results showed positive correlations and weak to moderate character. The emotions of contempt and happiness were significantly related to all the factors of the questionnaire. The emotions of sadness and surprise had significant correlations

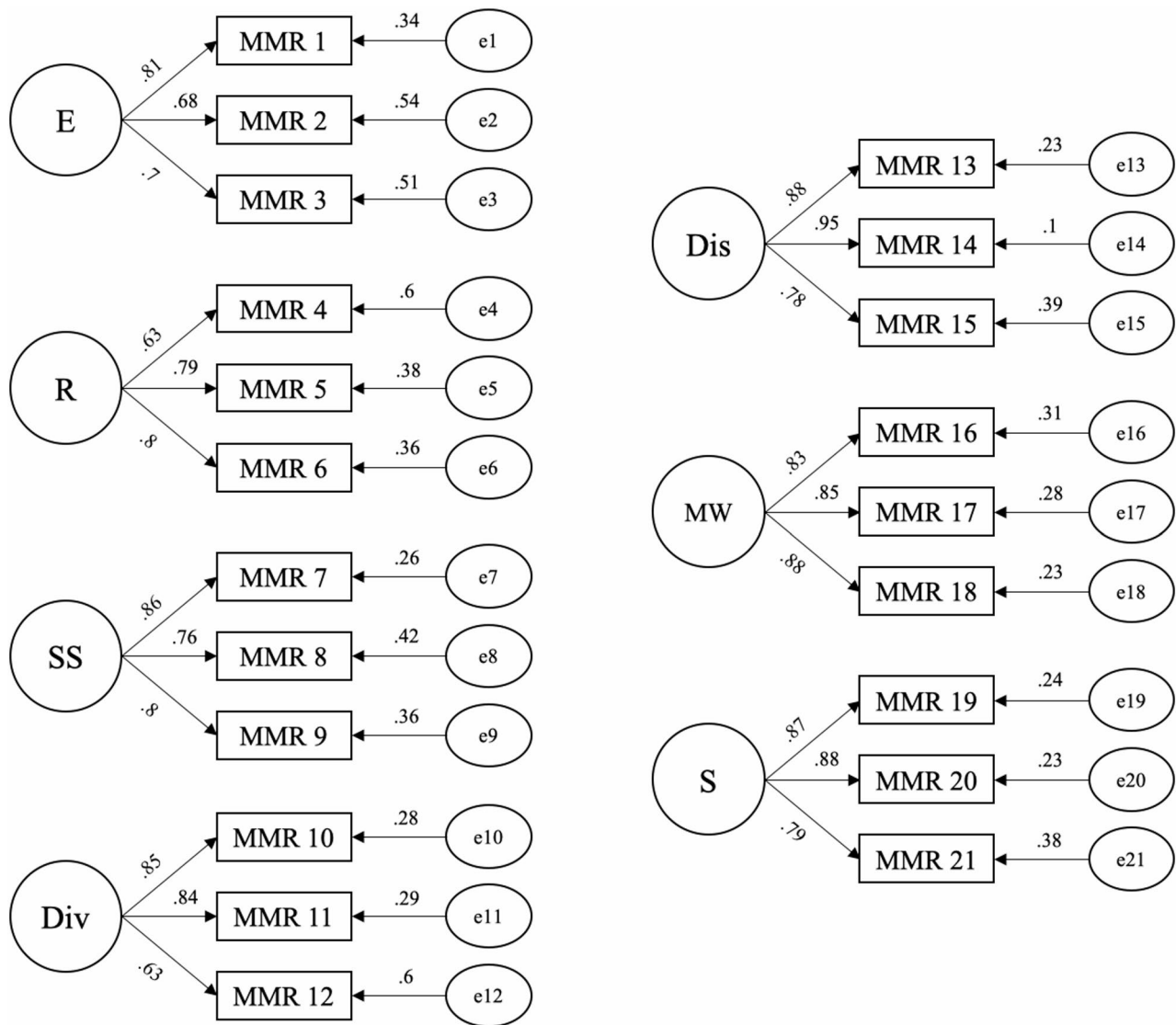

**Fig. 1** Factor model of the Spanish adaptation of the B-MMR. Note. *E* Entertainment, *R* Revival, *SS* Strong Sensation, *Div* Diversion, *Dis* Discharge, *MW* Mental Work, *S* Solace

**Table 2** B-MMR goodness-of-fit indices

Model	$\chi^2$	df	$\chi^2/df$	GFI	TLI	CFI	RMSEA (IC 90%)	SRMR
21 items	436.63*	168	2.6	0.91	0.95	0.96	0.06 (0.05, 0.07)	0.046

df Degrees of freedom, GFI Goodness of Fit Index, TLI Tucker-Lewis Index, CFI Comparative Fit Index, RMSEA Root Mean Square Error of Approximation, SRMR Standardized Root Mean Square Residual

\* $p < .001$

**Table 3** Reliability indices and average extracted variance (AVE) for the B-MMR

Estimation Method	E	R	SS	Div	Dis	MW	S
$\alpha$ by Cronbach	0.76	0.78	0.85	0.8	0.9	0.89	0.88
Composite reliability	0.77	0.79	0.85	0.82	0.91	0.89	0.88
AVE	0.54	0.55	0.65	0.61	0.75	0.73	0.72

*E* Entertainment, *R* Revival, *SS* Strong Sensation, *Div* Diversion, *Dis* Discharge, *MW* Mental Work, *S* Solace

**Table 4** Correlations among B-MMR factors versus the square root of the AVE

	E	R	SS	Div	Dis	MW	S
E	0.73						
R	0.61	0.74					
SS	0.45	0.51	0.81				
Div	0.52	0.68	0.6	0.78			
Dis	0.27	0.44	0.36	0.46	0.87		
MW	0.48	0.58	0.64	0.66	0.62	0.85	
S	0.47	0.62	0.64	0.69	0.67	0.84	0.85

E Entertainment, R Revival, SS Strong Sensation, Div Diversion, Dis Discharge, MW Mental Work, S Solace

All correlations were significant at the 0.01 level (bilateral)

**Table 5** Analysis of invariance according to the sex of the participants

Model	$\chi^2$	df	$\chi^2/df$	GFI	TLI	CFI	RMSEA (IC 90%)
Unconstrained	681.71 ( $p < .01$ )	336	2.03	0.87	0.93	0.94	0.05 (0.05, 0.06)
Constrained	705.77 ( $p < .01$ )	357	1.98	0.86	0.93	0.94	0.05 (0.04, 0.05)

**Table 6** External validity analysis with basic emotions

	Anger	Fear	Surprise	Sadness	Disgust	Contempt	Happiness
E	0.08	0.05	0.08	0.13**	0.06	0.19**	0.27**
R	0.07	0.04	0.11*	0.1	0.05	0.23**	0.24**
SS	0.08	0.1	0.11*	0.17**	0.06	0.34**	0.29**
Div	0.09	0.09	0.14**	0.11*	0.08	0.31**	0.32**
Dis	0.35**	0.2**	0.12*	0.33**	0.16**	0.26**	0.1*
MW	0.18**	0.13**	0.17**	0.24**	0.08	0.37**	0.28**
S	0.22**	0.1*	0.13**	0.26**	0.08	0.34**	0.27**

\*Correlation is significant at the 0.05 level (bilateral)

\*\*Correlation is significant at the 0.01 level (bilateral)

E Entertainment, R Revival, SS Strong Sensation, Div Diversion, Dis Discharge, MW Mental Work, S Solace

with almost all but one of the factors. The emotions of anger and fear were significantly correlated with three of the factors, and the emotion of disgust only showed a significant correlation.

## Discussion

The purpose of this research was to adapt the *Brief Music in Mood Regulation* (B-MMR) scale [48] to Spanish, thereby developing an instrument with solid psychometric indicators that enables its use in assessing mood regulation through music. The results obtained support the quality of the validated instrument, confirming the general hypothesis of this study. In turn, higher psychometric indices have been obtained in the Spanish version compared to those of the original scale in English.

Regarding the adjustment of the measurement model in Spanish, when replicating the original structure of the scale, the indicators were satisfactory according to the criteria established by Schermelleh-Engel et al. [51], both in terms of the global adjustment and the individual adjustment of each parameter [25]. In terms of reliability, the indicators were adequate in all model factors, both from the perspective of internal consistency [6] and composite reliability [8, 40].

In addition, the average variance extracted (AVE) indicators provided strong evidence of both convergent and discriminant validity [18]. Regarding convergent validity, all factors explained more than 50% of the variance in their respective indicators, with the remaining variance attributed to measurement error. As for discriminant validity, each construct shared more variance with its own indicators than with any other factor in the model.

Invariance analyses revealed that the structure of the Spanish version of the B-MMR is equivalent for both men and women. No significant differences were found between the models with and without constraints when calculating  $\chi^2_{dif}$  [7], or in the increase of CFI [12]. Finally, regarding the questionnaire's external validity, all the factors of the B-MMR showed statistically significant correlations with the perception of at least three basic emotions while listening to music.

The results of the correlations suggest that positive emotions tend to correlate more strongly with all dimensions compared to negative emotions, which is consistent with the use of music to generate and maintain pleasurable emotional states [50]. However, cognitive processing can be associated with both the elaboration of positive experiences and the re-evaluation of negative emotions

[44]. In other words, music not only influences mood but also helps in emotional understanding and processing.

Emotions (Contempt, Happiness) showed significant correlations with all dimensions, especially with “Mental Work” and “Strong Sensation”. Likewise, these emotions tend to correlate more strongly with all dimensions compared to negative emotions. Dimensions such as Entertainment, Revival, and Strong Sensation are more related to positive emotions, which is consistent with the use of music to generate and maintain pleasant emotional states [50].

The “Mental Work” and “Solace” dimensions show the highest correlations with multiple emotions, suggesting that they may be more related to emotional processing. “Mental Work” has the highest correlation with “Contempt” and “Happiness”, as well as “Sadness,” suggesting that cognitive processing may be associated with both the elaboration of positive experiences and the reappraisal of negative emotions [44]. In other words, music not only influences mood but also helps in emotional understanding and processing. “Solace” has significant correlations with “Sadness” and “Contempt”. This suggests that comfort-seeking may play a role in both the regulation of negative affect and the validation of positive affect, aligning with studies on social support and emotional coping [47].

“Entertainment” and “Revival” have lower correlations overall, but they stand out in terms of positive emotions, which suggests that positive emotions expand cognitive and motivational resources, facilitating the search for pleasurable experiences [36]. “Strong Sensation” and “Diversion” exhibit strong correlations with “Contempt” and “Happiness,” suggesting that both dimensions are associated with positive rather than negative emotions. This suggests that these strategies can amplify positive emotions, which is consistent with studies on maximizing emotional pleasure in recreational and artistic contexts [46].

Negative emotions (Anger, Fear, Sadness, Disgust) have moderate correlations with dimensions such as “Discharge” and “Mental Work”, indicating that they could be related to emotional regulation. “Discharge” has the highest correlation with “Anger” and “Sadness”, reflecting the idea that music can facilitate emotional expression and catharsis, as suggested by Saarikallio [46]. “Sadness” exhibits significant correlations with almost all dimensions, particularly with “Solace” and “Mental Work”, suggesting that sadness may be linked to support-seeking and cognitive processing. The relationship between “Discharge” and “Sadness” reinforces the idea that expressing negative emotions can help in mood regulation [45]. “Fear” has the lowest correlations overall, indicating that fear does not appear to be as closely linked to these dimensions as other emotions. “Disgust” has relatively low correlations with all dimensions, suggesting that

this emotion may not be as closely related to common regulation strategies as anger or sadness. This aligns with research indicating that disgust tends to trigger avoidance rather than active coping, and cognitive restructuring [29].

This study has a few limitations. The first of these is the use of self-assessment instruments to evaluate research variables, as they can often generate biased results due to the subjective nature of participant responses. In recent years, diagnostic imaging methods [28, 32] and psychophysiological indices [26] have been used to objectively assess how music influences mood and emotional states through listeners’ bodily responses. These assessments focus on parameters like heart rate variability, facial expressions, and brain activity related to different types of music. However, due to the limited accessibility of these methods, they are challenging to apply to large populations. Consequently, questionnaires remain a more accessible tool for measuring these effects. The selection of the sample did not follow a probabilistic sampling procedure, which may affect its representativeness. Most of the participants are young people, and some subgroups, such as university students, could have increased the sample size. Finally, when analysing the discriminant validity of the B-MMR, other instruments could have been included to evaluate related variables such as perceived well-being.

As Saarikallio [48] noted, the B-MMR scale assesses the general tendency to use music as a means of mood regulation, differentiating between seven regulatory strategies that refer to slightly different behavioural patterns regarding music use (p. 101). The fact that this instrument is concise, has a strong theoretical basis, is easily administered, and is a self-report measure is most valuable. It can be used in further investigations of mood regulation behaviours and other types of musical engagement (e.g., playing, singing, composing, improvising) as regulatory strategies from adolescence through adulthood. Researchers could also utilize the B-MMR to further explore the relationships between mood regulation strategies and other variables that are likely to influence them, such as musical training, music preferences, personality traits, and cultural context.

Further investigations should also test the B-MMR scale with older people. Laukka [33] found that older adults (aged 65 to 75 years) often use music to satisfy psychological needs, including emotional functions (such as pleasure, mood regulation, and relaxation) and aspects of their identity, sense of belonging, and sense of agency. Saarikallio [47] has already underlined that the scale is expected to be valid for older people due to the general nature of music-related mood regulation and the range of different regulatory strategies. In Saarikallio [46], the initial scale, MMR, was developed for young people,

with participants having a mean age of 15.01 (age range: 10–20). In Saarikallio [48], the mean age was 23.97 years (age range: 19–44), with 75% of the participants being 25 years or younger. In this study, the sample consisted mainly of young adults, with a mean age of 24.07 years. Although a few older respondents participated (age range: 16–75), 76.9% of the participants were 25 years or younger. Although the age range has increased, the mean age in these studies still relates to younger people. Additionally, from a practical perspective, this instrument offers great potential to be applied in various areas, ranging from everyday contexts to educational settings, healthcare, and professional work. Future studies could also explore cross-cultural validations of this instrument. This would allow us to verify the adaptability and reliability of the scale across various populations, in addition to the English [48], Italian [2], and the Spanish version presented in this study.

Music plays a significant role in emotional well-being, stress management, and psychological health [3, 10, 49]. Thus, understanding how individuals use music to regulate emotions can provide insights into coping mechanisms, emotional resilience, and mental health interventions. Moreover, if researchers and practitioners (e.g., music therapists and psychologists) consider the regulatory strategies outlined in B-MMR, they can gain a deeper understanding of how music affects emotional states, develop personalized therapeutic interventions, and help individuals utilize music more effectively for mental and emotional well-being.

#### Acknowledgements

We would like to acknowledge the teaching staff and management team of the educational centres, and all participants in this study.

#### Clinical trial number

Not applicable.

#### Authors' contributions

Conceptualization, M.A.H.; Methodology, D.T.L.; Formal analysis, D.T.L.; Investigation, M.A.H.; Data curation, M.A.H.; Writing—original draft preparation, M.A.H., D.T.L. and A.I.P.; Writing—review and editing, M.A.H., D.T.L. and A.I.P.; Supervision, M.A.H.; Project administration, M.A.H. All authors have read and agreed to the published version of the manuscript.

#### Funding

The publication of this scientific work has been funded by the Call for Grants for Scientific Publication in Prestigious Publishing Media of the Universidad Internacional de la Rioja. The research was developed within the framework of CESEM (Centre for Music Studies – UID/00693) and received no funding.

#### Data availability

The dataset that supports the findings of this study is available from the corresponding author upon reasonable request.

#### Declarations

##### Ethics approval and consent to participate

The study was conducted in accordance with the Declaration of Helsinki and approved by the Ethics Committee of the University of A Coruña (UDC) (#2023-029, March 7, 2024) and the Ethics Committee of the Xunta of

Galicia (December 19, 2023). Participants were informed of their rights to confidentiality and the option of voluntary participation. Informed consent was obtained from all participants involved in the study. There were no participants under the age of 16 in the study, so it was not necessary to ask for permission from parents or legal guardians.

##### Consent for publication

Not applicable.

##### Competing interests

The authors declare no competing interests.

Received: 5 May 2025 / Accepted: 29 January 2026

Published online: 31 March 2026

#### References

- Alluri V, Toivaiainen P, Burunat I, Kliuchko M, Vuust P, Brattico E. Connectivity patterns during music listening: evidence for action-based processing in musicians. *Hum Brain Mapp*. 2017;38(6):2955. <https://doi.org/10.1002/hbm.23565>.
- Ansani A, Mallia L, Saarikallio S. Music in mood regulation brief scale (B-MMR): Italian version and insights on musical preferences, expertise, and reward experiences. *Music Perception: Interdisciplinary J*. 2025;42(4):389–405. <https://doi.org/10.1525/mp.2025.2326557>.
- Baltazar M, Västfjäll D, Asutay E, Koppel L, Saarikallio S. Is it me or the music? Stress reduction and the role of regulation strategies and music. *Music amp; Sci*. 2019;2. <https://doi.org/10.1177/2059204319844161>.
- Balluerka N, Gorostiaga A, Alonso-Arbiol I, Haranburu M. The adaptation of measurement instruments from one culture to another: a practical perspective. *Psicothema*. 2007;19(1):124–33.
- Bradt J, Dileo C, Magill L, Teague A. Music interventions for improving psychological and physical outcomes in cancer patients. *Cochrane Database Syst Rev*. 2016;8CD006911. <https://doi.org/10.1002/14651858.cd006911.pub3>.
- Bonett DG, Wright TA. Cronbach's alpha reliability: interval estimation, hypothesis testing, and sample size planning. *J Organizational Behav*. 2015;36(1):3–15. <https://doi.org/10.1002/job.1960>.
- Byrne BM. (2016). *Structural Equation Modeling with AMOS*. Routledge. <https://doi.org/10.4324/9781315757421>
- Carmines EG, Zeller RA. Reliability and validity assessment. Sage; 1979. <https://doi.org/10.4135/9781412985642>.
- Carraturo G, Ferreri L, Vuust P, Matera F, Brattico E. Empathy but not musicality is at the root of musical reward: A behavioral study with adults and children. *Psychol Music*. 2022;50(6):2001–20. <https://doi.org/10.1177/03057356221081168>.
- Cascarino E, Knight T, Macdonald JA. The music gets through: experiences of classical composers and observations of hospitalized adolescents in a music-based intervention. *Psychol Music*. 2021;50(5):1373–89. <https://doi.org/10.1177/03057356211042079>.
- Eerola T. Music communicates affects, not basic emotions – A constructionist account of attribution of emotional meanings to music. *Front Psychol*. 2018;9:326516. <https://doi.org/10.3389/fpsyg.2018.00215>.
- Cheung GW, Rensvold RB. Evaluating goodness-of-fit indexes for testing measurement invariance. *Struct Equation Modeling: Multidisciplinary J*. 2002;9:233–55. [https://doi.org/10.1207/s15328007sem0902\\_5](https://doi.org/10.1207/s15328007sem0902_5).
- Cochran WG. Sampling techniques. Wiley; 2007.
- Ekman P. Basic emotions. In: Dalgleish T, Power MJ, editors. *Handbook of cognition and emotion*. John Wiley & Sons Ltd; 1999. pp. 45–60. <https://doi.org/10.1002/0470013494.ch3>.
- Ekman P, Cordaro D. What is meant by calling emotions basic. *Emot Rev*. 2011;3(4):364–70. <https://doi.org/10.1177/1754073911410740>.
- Elvers P, Fischinger T, Steffens J. Music listening as self-enhancement: effects of empowering music on momentary explicit and implicit self-esteem. *Psychol Music*. 2018;46(3):307–25. <https://doi.org/10.1177/0305735617707354>.
- Esteve-Faubel RP, Aparicio-Flores MP, Cavia-Naya V, Esteve-Faubel JM. Emotional intelligence perceived academic self-efficacy, and perfectionistic automatic thoughts as predictors of aesthetic-musical awareness in late adolescence. *Front Psychol*. 2021;12:733025. <https://doi.org/10.3389/fpsyg.2021.733025>.

18. Fornell C, Larcker DF. Evaluating structural equation models with unobservable variables and measurement error. *J Mark Res.* 1981;18(1):39–50. <https://doi.org/10.1177/002224378101800104>.
19. Greb F, Schlotz W, Steffens J. Personal and situational influences on the functions of music listening. *Psychol Music.* 2018;46(6):763. <https://doi.org/10.1177/0305735617724883>.
20. Groarke JM, Hogan MJ. Listening to self-chosen music regulates induced negative affect for both younger and older adults. *PLoS ONE.* 2019;14(6). <http://doi.org/10.1371/journal.pone.0218017>.
21. Hargreaves DJ, North AC. Experimental aesthetics and liking for music. In: Juslin PN, Sloboda JA, editors. *Handbook of music and emotion: Theory, research, applications.* Oxford University Press; 2010. pp. 515–46.
22. Hernández A, Hidalgo MD, Hambleton RK, Gómez-Benito J. International test commission guidelines for test adaptation: A criterion checklist. *Psicothema.* 2020;32(3):390–8. <https://doi.org/10.7334/psicothema2019.306>.
23. Hernandez-Ruiz E, James B, Noll J, Chrysikou EG. What makes music relaxing? An investigation into musical elements. *Psychol Music.* 2020;48(3):327–43. <https://doi.org/10.1177/0305735618798027>.
24. Herrera L, Cremades R, Lorenzo O. Preferencias musicales de los estudiantes de Educación Secundaria Obligatoria: influencia de la educación formal e informal. *Culture Educ.* 2010;22(1):37–51. <https://doi.org/10.1174/113564010790935222>.
25. Hu LT, Bentler PM. Cutoff criteria for fit indexes in covariance structure analysis: conventional criteria versus new alternatives. *Struct Equation Modeling: Multidisciplinary J.* 2009;6(1):1–55. <https://doi.org/10.1080/10705519909540118>.
26. Juslin PN, Harmat L, Eerola T. What makes music emotionally significant? Exploring the underlying mechanisms. *Psychol Music.* 2014;42(4):599–623. <https://doi.org/10.1177/0305735613484548>.
27. Juslin PN, Barradas G, Eerola T. From sound to significance: exploring the mechanisms underlying emotional reactions to music. *Am J Psychol.* 2015;128(3):281–304. <https://doi.org/10.5406/amerjpsyc.128.3.0281>.
28. Kliuchko M, Brattico E, Gold BP, Tervaniemi M, Bogert B, Toiviainen P, Vuust P. Fractionating auditory priors: A neural dissociation between active and passive experience of musical sounds. *PLoS ONE.* 2019;14(5). <https://doi.org/10.1371/journal.pone.0216499>.
29. Knowles KA, Cox RC, Armstrong T, Olatunji BO. Cognitive mechanisms of disgust in the development and maintenance of psychopathology: A qualitative review and synthesis. *Clin Psychol Rev.* 2019;69:30–50. <https://doi.org/10.1016/j.cpr.2028.06.002>.
30. Krause AE, North AC, Hewitt LY. Music-listening in everyday life: devices and choice. *Psychol Music.* 2015;43(2):155–70. <https://doi.org/10.1177/0305735613496860>.
31. Krause AE, Scott WG, Flynn S, Foong B, Goh K, Wake S, Miller D, Garvey D. Listening to music to cope everyday stressor. *Musicae Scientiae.* 2021;27(1):176–92. <https://doi.org/10.1177/10298649211030318>.
32. Koelsch S. A coordinate-based meta-analysis of music-evoked emotions. *NeuroImage.* 2020;223:117350. <https://doi.org/10.1016/j.neuroimage.2020.117350>.
33. Laukka P. Uses of music and psychological well-being among the elderly. *J Happiness Stud.* 2007;8(2):215–41. <https://doi.org/10.1007/s10902-006-9024-3>.
34. Liljeström S, Juslin PN, Västfjäll D. Experimental evidence of the roles of music choice, social context, and listener personality in emotional reactions to music. *Psychol Music.* 2013;41(5):579–99. <https://doi.org/10.1177/0305735612440615>.
35. Longhi E, Pickett N, Hargreaves DJ. Wellbeing and hospitalized children: can music help? *Psychol Music.* 2015;43(2):188–96. <https://doi.org/10.1177/0305735613499781>.
36. Lonsdale AJ, North AC. Why do we listen to music? A uses and gratifications analysis. *Br J Psychol.* 2011;102(1):108–34. <https://doi.org/10.1348/000712610X506831>.
37. Memon MA, Thurasamy R, Ting H, Cheah JH. Purposeful sampling: A review and guidelines for quantitative research. *J Appl Struct Equation Model.* 2024;9(1):1–23. [https://doi.org/10.47263/JASEM.9\(1\)01](https://doi.org/10.47263/JASEM.9(1)01).
38. Muñoz J, Elosua P, Hambleton RK. Guidelines for the translation and adaptation of the tests: second edition. *Psicothema.* 2013;25(2):151–7. <https://doi.org/10.7334/psicothema2013.24>.
39. Nawaz S, Omigie D. Investigating the interaction of pleasantness and arousal and the role of aesthetic emotions on episodic memory using a musical what-where-when paradigm. *Cogn Emot.* 2023;37(2):320–8. <https://doi.org/10.1080/02699931.2023.2185206>.
40. Nunnally JC. *Psychometric theory.* McGraw-Hill; 1978.
41. Omigie D. Dopamine and epistemic curiosity in music listening. *Cogn Neurosci.* 2015;6(4):222–4. <https://doi.org/10.1080/17588928.2015.1051013>.
42. Omigie D, Frieler K, Bär C, Muralikrishnan R, Wald-Fuhrmann M, Fischinger T. Experiencing musical beauty: emotional subtypes and their physiological and musico-acoustic correlates. *Psychol Aesthet Creativity Arts.* 2021;15(2):197–215. <https://doi.org/10.1037/aca0000271>.
43. Park KS, Hass CJ, Fawver B, Lee H, Janelle CM. Emotional States influence forward gait during music listening based on familiarity with music selections. *Hum Mov Sci.* 2019;66:53–62. <https://doi.org/10.1016/j.humov.2019.03.004>.
44. Reybrouck M, Eerola T. Music and its inductive power: A Psychobiological and evolutionary approach to musical emotions. *Front Psychol.* 2017;8:494. <https://doi.org/10.3389/fpsyg.2017.00494>.
45. Rimé B. Emotion elicits the social sharing of emotion: theory and empirical review. *Emot Rev.* 2009;1(1):60–85. <https://doi.org/10.1177/1754073908097189>.
46. Saarikallio SH. Music in mood regulation: initial scale development. *Musicae Sci.* 2008;12(2):291–309. <https://doi.org/10.1177/102986490801200206>.
47. Saarikallio S. Music as emotional self-regulation throughout adulthood. *Psychol Music.* 2011;39(3):307–27. <https://doi.org/10.1177/0305735610374894>.
48. Saarikallio S. Development and validation of the brief music in mood regulation scale (B-MMR). *Music Percept.* 2012;30(1):97–105. <https://doi.org/10.1525/mp.2012.30.1.97>.
49. Saarikallio SH, Randall WM, Baltazar M. Music listening for supporting adolescents' sense of agency in daily life. *Front Psychol.* 2020;10(492399). <https://doi.org/10.3389/fpsyg.2019.02911>.
50. Saarikallio S, Erkkilä J. The role of music in adolescents' mood regulation. *Psychol Music.* 2007;35(1):88–109. <https://doi.org/10.1177/0305735607068889>.
51. Schermelleh-Engel K, Moosbrugger H, Müller H. Evaluating the fit of structural equation models: tests of significance and descriptive goodness-of-fit measures. *Methods Psychol Res Online.* 2003;8(2):23–74.
52. Schubert E, Hargreaves DJ, North AC. A dynamically minimalist cognitive explanation of musical preference: is familiarity everything? *Front Psychol.* 2014;5:57528. <https://doi.org/10.3389/fpsyg.2014.00038>.
53. Sloboda, O., Neil. Music as an emotion regulation strategy: an examination of genres of music and their roles in emotion regulation given the powerful emotional effects of music, people might want use music to regulate their emotions in several possible. *Psychol Music.* 2019;47(1):144. <https://doi.org/10.1177/0305735617734627>.

## Publisher's note

Springer Nature remains neutral with regard to jurisdictional claims in published maps and institutional affiliations.